

≡ ECOFLOW

User Manual

V1.1

Issue Date
2024-09-02

EcoFlow PowerGlow Smart Immersion
Heater

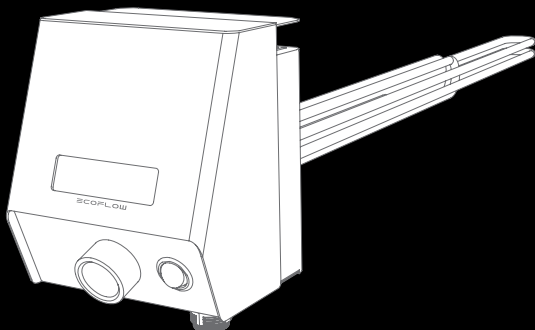

CONTENTS

1	Safety Instructions	5	System Operation
1	Disclaimer	5	System Power-On
1	Statement	5	LCD Display
1	Symbol Conventions	5	Setting Temperature
1	General Requirements	5	App Control
1	Personnel Requirements	5	For End User
1	Electrical Safety	5	For Installer
1	Installation Environment Requirements	6	Setting Manual Mode
2	Disposal	6	Setting Smart Mode
3	Pre-Installation Check	6	Scheduled Tank Sterilization
3	Checking Outer Packing	7	Maintenance
3	Checking Deliverables	7	System Power-Off
3	Product Storage	7	Routine Maintenance
3	Product Introduction	7	Troubleshooting
3	Function	7	Decommissioning
3	Integrating EcoFlow PowerGlow to EcoFlow PowerOcean System	7	Removing an Immersion Heater
3	Integrating EcoFlow PowerGlow to EcoFlow PowerOcean DC FIT System	7	Disposing an Immersion Heater
3	Integrating EcoFlow PowerGlow to Third-Party PV system	8	Technical Parameters
3	Working Principles		
4	Label Description		
4	Appearance		
5	System Installation		
5	Electrical Connection		
5	System Commissioning		

Safety Instructions

DISCLAIMER

Read this user manual carefully before using the product to ensure that you completely understand the product and can correctly use it. After reading this user manual, keep it properly for future reference. Improper use of this product may cause serious injury to yourself or others, or cause product damage and property loss. Once you use this product, it is deemed that you understand, approve and accept all the terms and content in this document. EcoFlow is not liable for any loss caused by the user's failure to use this product in compliance with this user manual. In compliance with laws and regulations, EcoFlow reserves the right to final interpretation of this document and all documents related to this product. This document is subject to changes (updates, revisions, or termination) without prior notice. Please visit EcoFlow's official website to obtain the latest product information.



STATEMENT

Follow local laws and regulations when installing, operating, or maintaining the equipment. The safety instructions in this manual are only supplements to local laws and regulations. Ensure that the equipment is used in environments that meet its design specifications. Otherwise, the equipment may become faulty, and the resulting equipment malfunction, component damage, personal injuries, or property damage are not covered under the warranty. EcoFlow will not be liable for any consequences of the following circumstances:

- Operation beyond the conditions specified in this document
- Unauthorized modifications to the product or software code or removal of the product
- Failure to follow the operation instructions and safety precautions on the product and in this document
- Equipment damage due to force majeure, such as earthquakes, fire, and storms
- Damage caused during transportation by the customer
- Storage conditions that do not meet the requirements specified in this document.
- Damage caused by calcium deposits on heating element.
- Damage caused by corrosion on heating element.

SYMBOL CONVENTIONS

This is a safety warning symbol. Such safety information alerts you to hazards that can be lethal to you and others, and that can cause damages to the equipment. All safety information is preceded by safety warning symbols and hazard words, including: "DANGER", "WARNING", "CAUTION", and "NOTICE". The "DANGER", "WARNING", "CAUTION", and "NOTICE" statements in this manual do not cover all the safety instructions. They are only supplements to the safety instructions.

Symbol	Description
 DANGER	Indicates a hazard with a high level of risk which, if not avoided, will result in death or serious injury.
 WARNING	Indicates a hazard with a medium level of risk which, if not avoided, could result in death or serious injury.
 CAUTION	Indicates a hazard with a low level of risk which, if not avoided, could result in minor or moderate injury.
 NOTICE	Indicates a potentially hazardous situation which, if not avoided, could result in equipment damage, data loss, performance deterioration, or unanticipated results. NOTICE is used to address practices not related to personal injury.

GENERAL REQUIREMENTS

DANGER

- Do not work with power on during installation.
- Wear proper PPE (Personal protective equipment) before any operations.

CAUTION

1. The EcoFlow PowerGlow Smart Immersion Heater (hereinafter referred to as EcoFlow PowerGlow) is an electrical device for heating water in heat exchange closed water tanks, which is intended for indoor installation.
2. Intended use also includes observing the operating instructions and complying with the maintenance requirements. Only use the product when it is in perfect technical condition.
3. Use the product as intended and in a safety-conscious manner. Have faults and damage that could impair safety rectified immediately by EcoFlow or a certified EcoFlow partner.
4. If the power cord of this equipment is damaged, it must be replaced by the manufacturer, customer service department or qualified personnel to prevent a safety hazard.

5. Do not touch the exposed cable with your hands.
6. Make sure the cables, connectors and ports are dry before starting up the equipment. Make sure all three are connected securely.
7. Tighten the screws to the specified torque using tools when installing the equipment.
8. After installing the equipment, remove the remnants of the device installation area, such as cardboard boxes, foam, plastic, wire ties, stripped insulation materials, etc.
9. All warning label and nameplates on the equipment should be visible after installation is complete. Do not scrawl, damage, or block any warning label on the device.
10. Do not open the host panel of the equipment without permission.
11. Do not reverse engineer, decompile, disassemble, adapt, add code to the device software or alter the device software in any other way. Any other operation that violates the original design specifications of the device hardware and software is not allowed.
12. If there is a probability of personal injury or equipment damage during operations on the equipment, immediately stop the operations, take feasible protective measures.
13. Use tools correctly to avoid hurting people or damaging the equipment.
14. Use insulated tools when operating equipment and wear personal protective equipment to ensure personal safety. Wear anti-static gloves, clothing and wristbands when touching electronic devices to protect equipment from damage.
15. Prior to performing any work on the equipment, always disconnect it from all power.
16. Do not connect loads between this equipment and the AC switch that directly connects to the equipment.
17. Dismantling, manipulating or deactivating the safety devices is prohibited.
18. This appliance can be used by children aged from 8 years and above and persons with reduced physical, sensory or mental capabilities or lack of experience and knowledge if they have been given supervision or instruction concerning use of the appliance in a safe way and understand the hazards involved. Children shall not play with the appliance. Cleaning and user maintenance shall not be made by children without supervision.

PERSONNEL REQUIREMENTS

1. Personnel who plan to install or maintain EcoFlow equipment must receive thorough training, understand all necessary safety precautions, and be able to correctly perform all operations.
2. Only qualified professionals are allowed to install, operate, and maintain the equipment.
3. Personnel who will operate the equipment, including operators, trained personnel, and professionals, should possess the local national required qualifications in special operations such as high-voltage operations, working at heights, and operations of special equipment.



Professionals: personnel who are trained or experienced in equipment operations and are clear of the sources and degree of various potential hazards in equipment installation, operation, and maintenance.

ELECTRICAL SAFETY

GROUNDING

1. For the equipment that needs to be grounded, install the ground cable first when installing the equipment and remove the ground cable last when removing the equipment.
2. A permanent earthing of the hot water tank that the EcoFlow PowerGlow mounted to is mandatory.
3. Do not damage the ground conductor.
4. Do not operate the equipment in the absence of a properly installed ground conductor.
5. Ensure that the equipment is connected permanently to the protective ground. Before operating the equipment, check its electrical connection to ensure that it is securely grounded.
6. The PE pole of the AC IN terminal must be grounded.

GENERAL REQUIREMENTS

WARNING

- Before connecting cables, ensure that the equipment is intact. Otherwise, electric shocks or fire may occur.
1. Ensure that all electrical connections comply with local electrical standards.
 2. Ensure that the cables installer prepared meet local regulations.
 3. Use dedicated insulated tools when performing high-voltage operations.
 4. Before connecting a power cable, check that the label on the power cable is correct. When fabricating cables and installing connectors on site, follow the respective instructions in this manual and the requirements of local laws and regulations.
 5. Before operating the equipment, disconnect all power to the equipment and wait for the corresponding delayed discharge time to ensure that the equipment is completely de-energized.

CABLING

1. The cabling path must avoid the equipment cooling system and parts.
2. When routing cables, ensure that a distance of at least 30 mm exists between the cables and heat-generating components or areas. This prevents damage to the insulation layer of the cables.
3. Bind cables of the same type together. When routing cables of different types, ensure that they are at least 30 mm away from each other. Mutual entanglement or cross-deployment is not allowed.

INSTALLATION ENVIRONMENT REQUIREMENTS

1. Ensure that the equipment is installed in a well ventilated, and dry environment.
2. The ventilation holes of the housing must not be blocked.
3. When used in water containing limescale, the EcoFlow PowerGlow must be descaled regularly.
4. To prevent corrosion damage to enameled or coated tanks, the tubular heating elements of the screw-in heating element are electrically insulated from the tank and have a defined conductive connection via a resistor, which increases the service life of the protective anode and the screw-in heating element.
5. Ensure that the installation site is level, vibration-free and free from contamination.
6. To prevent fire due to high temperature, ensure that the ventilation vents or heat dissipation system are not blocked when the equipment is under operation.
7. The water tank that the EcoFlow PowerGlow mounted needs to be configured with a pressure-relief device, which is to be connected to a discharge pipe with a steady downward inclination in a frost-free environment. For installation details about a pressure-relief device, refer to the installation guide provided by its manufacturer.
8. Ensure that the heating elements are completely surrounded by water, and must not be used in dry mode under any circumstances. Subsequently, the tank must be checked for leakage.
9. Do not expose the equipment to flammable or explosive gas or smoke. Do not perform any operation on the equipment in such environments.
10. Do not place the equipment next to any heat source, or fire source, and not to perform any operation on the equipment next to that heat source, fire source.
11. Do not install the equipment in ammonia-contaminated environments.
12. Do not install the equipment in dusty environment.
13. The ventilation holes of the housing must not be blocked.
14. Avoid exposure to intense heat, cold, rain, snow or direct sunlight during storage and operation.

DISPOSAL

For information on the disposal of electrical and electronic equipment, please visit the following website:

<https://eu.ecoflow.com/pages/electronic-devices-disposal>



This marking indicates that this product should not be disposed of with other household waste within the EU. Recycle this product properly to prevent possible damage to the environment or a risk to human health via uncontrolled waste disposal and in order to promote the sustainable reuse of material resources. Please return your used product to an appropriate collection point or contact the retailer where you purchased this product. Your retailer will accept used products and return them to an environmentally-sound recycling facility.



Hereby, EcoFlow Inc. declares that the radio equipment type Smart Immersion Heater is in compliance with Directive 2014/53/EU. The full text of the EU declaration of conformity is available at the following Internet address:

eu: <http://www.ecoflow.com/eu/eu-compliance>

de: <http://www.ecoflow.com/de/eu-compliance>

fr: <http://www.ecoflow.com/fr/eu-compliance>

Pre-Installation Check

CHECKING OUTER PACKING

Before unpacking the equipment, check the outer packing for damage, such as holes and cracks, and check the model. If any damage is found, do not unpack the package and contact your supplier as soon as possible.

CHECKING DELIVERABLES

After unpacking the equipment, check that the deliverables are intact and complete. If any item is missing or damaged, contact your dealer.



For details about the number of accessories delivered with the equipment, see **What's In The Box** in the Installation Guide.

Product Storage

The following requirements should be met if the equipment is not put into use directly:

1. Do not unpack the equipment.
2. Keep the storage temperature at -20°C to $+70^{\circ}\text{C}$ and the humidity at 0%-99% (Non-Condensing).
3. The product should be stored in a clean and dry place and be protected from dust and water vapor corrosion.
4. Do not stack heavy items on the equipment to avoid equipment damage.
5. Do not place this product near water, fire or other heat sources (heaters, direct sunlight, gas ovens, etc.).
6. During the storage period, check the equipment periodically.
7. If the equipment has been stored for a long time (more than 6 months), it must be checked and tested by professionals before being put into use.

Product Introduction

FUNCTION

EcoFlow PowerGlow is a linearly controlled water heating device for grid-connected photovoltaic systems, such as EcoFlow PowerOcean system or third-party PV system. When integrated with the EcoFlow PowerOcean system, charging of the battery storage has priority. Once the battery is fully charged, the EcoFlow PowerGlow starts using surplus PV energy for hot water heating, implementing intelligent scheduling of energy use via EcoFlow App. With the self-powered mode of the EcoFlow PowerOcean system, the self-consumption rate of the system, and the self-sufficiency rate of residential energy will be greatly improved, reducing electricity & gas costs.

INTEGRATING ECOFLOW POWERGLOW TO ECOFLOW POWEROCEAN SYSTEM

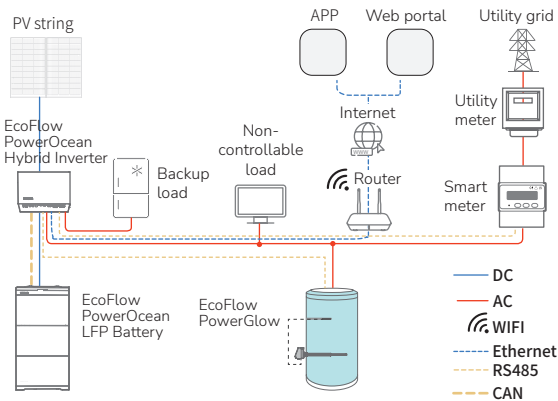

INTEGRATING ECOFLOW POWERGLOW TO ECOFLOW POWEROCEAN DC FIT SYSTEM

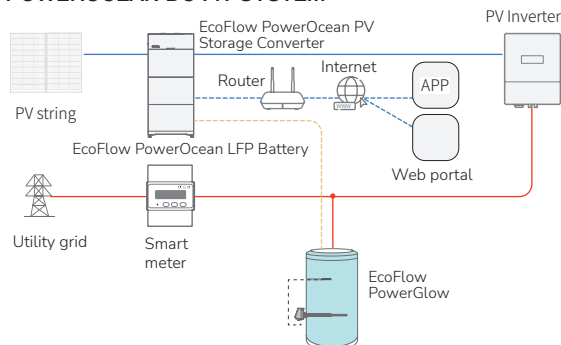

INTEGRATING ECOFLOW POWERGLOW TO THIRD-PARTY PV SYSTEM

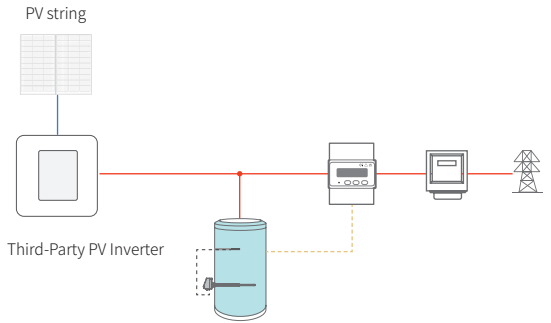

WORKING PRINCIPLES

EcoFlow PowerGlow Smart Immersion Heater has an electrical resistant heating element encased in a sheath. After energized, the heating element is activated by AC power, which is converted from PV excess through an inverter circuit, it heats its enclosing jacket that heats the sheath, which heats the water in tank.

LABEL DESCRIPTION

ENCLOSURE LABELS

Icon	Name	Meaning
	Electric shock warning	Caution, risk of electric shock
	Burn warning	Do not touch a running equipment because the enclosure is hot when the equipment is running.
	Refer to documentation	Reminds operators to refer to the documents delivered with the equipment.
	Grounding	Indicates the position for connecting the protective earthing (PE) cable.
	Operation warning	Do not remove the AC/DC connector when the equipment is running.
	WEEE designation	Do not dispose of the product together with the household waste but in accordance with the disposal regulations for electronic waste applicable at the installation site.
	CE marking	The product complies with the requirements of the applicable EU directives.
	Serial Number	Indicates the Serial Number of the equipment.



The labels are for reference only.

APPEARANCE

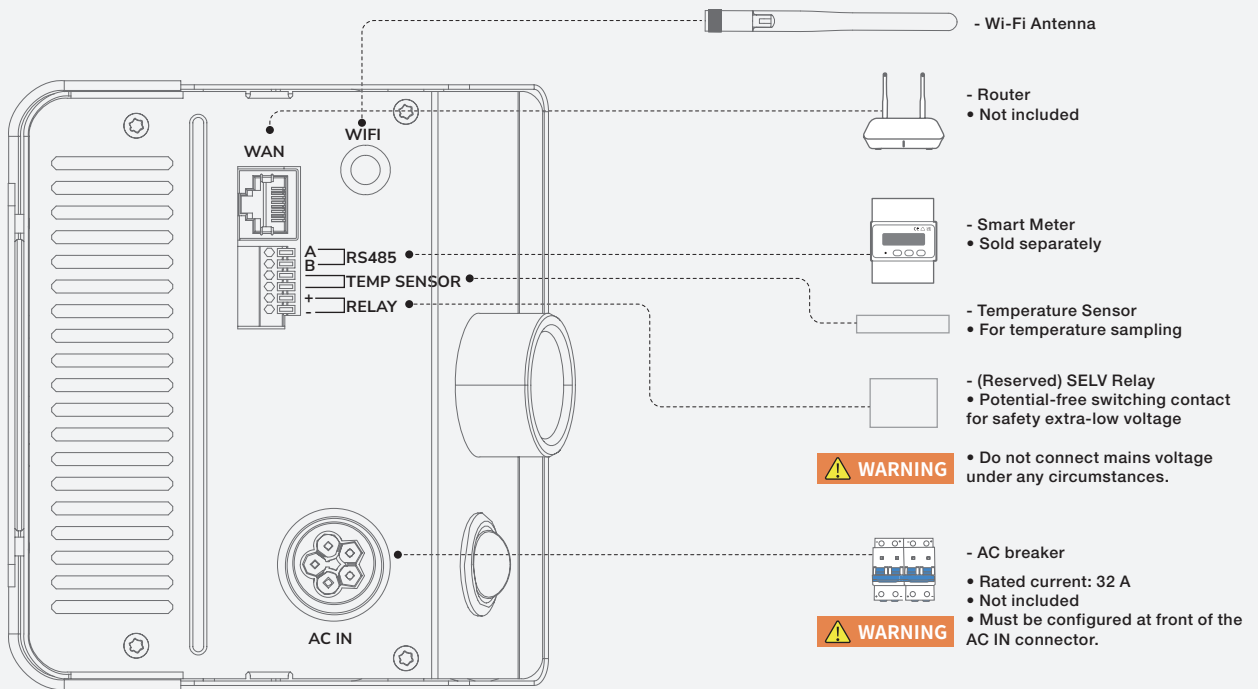
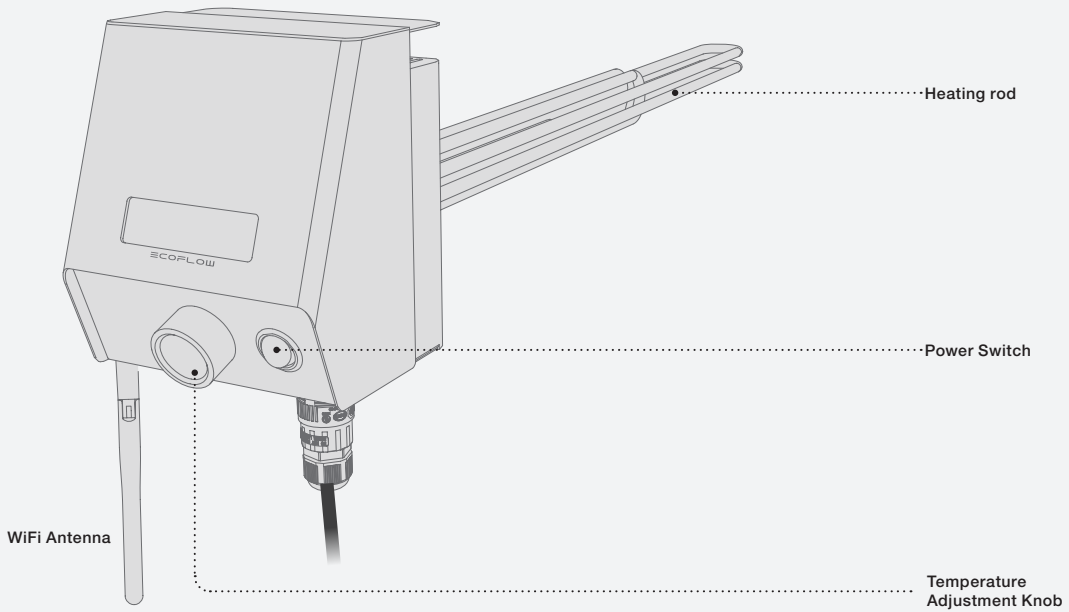

System Installation

For System Installation, please refer to Installation Guide delivered with the equipment.

Electrical Connection

For Electrical Connection, please refer to Installation Guide delivered with the equipment.

System Commissioning

For System Commissioning, please refer to Installation Guide delivered with the equipment.

System Operation

SYSTEM POWER-ON

PROCEDURE (INTEGRATED WITH POWEROCEAN)

1. Power on the PowerOcean system. See the installation guide that comes with PowerOcean.
2. Power on the AC breaker/RCD that directly connects to the device.
3. Set the POWER SWITCH to I position.
4. Observe the LCD display to check the operating status, normally real-time water temperature is displayed.

PROCEDURE (INTEGRATED WITH THIRD-PARTY PV SYSTEM)

1. Power on the third-party PV system.
2. Power on the AC breaker/RCD that directly connects to the device.
3. Set the POWER SWITCH to I position.
4. Observe the LCD display to check the operating status, normally real-time water temperature is displayed.

NOTICE

- During the initial commissioning, you need to press the knob once or send a power-on command via EcoFlow app to activate the heating mode of the device.

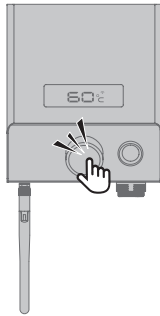

	Network failure
	Power off

NOTICE

- If the LCD indicates a faulty status, visit the EcoFlow app to retrieve the error code for troubleshooting.

SETTING TEMPERATURE

METHOD 1: VIA USING THE TEMPERATURE ADJUSTMENT KNOB

Rotate the Temperature Adjustment Knob until the LCD displays your desired temperature, and then press the knob once to complete setting process, with the digitals blinking twice.

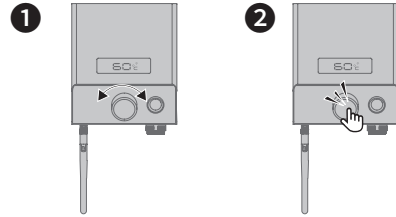

METHOD 2: VIA ECOFLOW APP

Refer to the App Control section in the installation guide that comes together with the equipment.

App Control

EcoFlow provides thorough support for the system. Both the end user and installer benefit from our comprehensive guides and resources.

FOR END USER

Effortlessly manage, monitor, and control your PowerOcean devices through a sleek, user-friendly interface via app or web management. Access real-time energy data, detailed power generation, storage and energy bills savings anytime and anywhere. Professional technical support is also readily available when needed.

- EcoFlow App Management

Scan the QR code or download at <https://download.ecoflow.com/app>

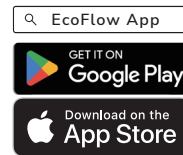
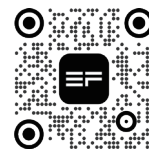

LCD DISPLAY

Power On/Off Status	Description
	Startup, indicating real-time water temperature
	Indicating a desired water temperature when rotating the Temperature Adjustment Knob
	The digitals blink twice when pushing the knob once to setup the desired water temperature
	Indicating a faulty status
	Over-the-air update is in progress
	Not connected to network

PRIVACY POLICY

By using EcoFlow Products, Applications and Services, you consent to the EcoFlow Term of Use and Privacy Policy, which you can access via the "About" section of the "User" page on the EcoFlow App or on the official EcoFlow website at <https://www.ecoflow.com/policy/terms-of-use> and <https://www.ecoflow.com/policy/privacy-policy>

FOR INSTALLER

Streamline the commissioning process, monitor device status in real-time, access detailed troubleshooting solutions for system faults and also offer customer support from EcoFlow professional support team.

- EcoFlow Pro App Management

Scan the QR code or download at <https://download.ecoflow.com/ecoflowproapp>

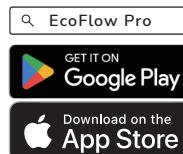

SETTING MANUAL MODE

- Manual mode applies to time frames when / areas where the power from PV strings is insufficient.
- In Manual mode, the PowerGlow will operate at the set power, drawing power from both grid and solar power, even when there is no surplus solar power. This means that the device is still able to heat water even when the light intensity is low.
- Example: When the sunlight becomes weak, the PV module outputs 110 W surplus power, the PowerGlow consumes 8438 W power, and draws 8328 W power from the grid.

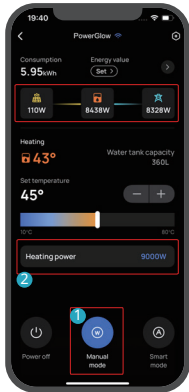

SETTING SMART MODE

- Smart mode applies to time frames when / areas where the power from PV strings is sufficient.
- In Smart mode, the PowerGlow will switch between solar power and the grid for drawing power based on the data reported by the linked meter, fully utilizing solar power, and minimizing solar power or even 0 W fed to the grid.
- Example: When the sunlight is sufficient, the PV module outputs 8007 W surplus power, the PowerGlow consumes 8007 W power, and draws 0 W power from the grid.

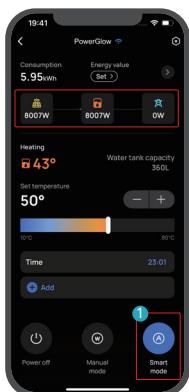

- In Smart mode, you can also set up to two scheduled heating tasks for your convenience. When the sunlight is insufficient, the PowerGlow will drawing power from both solar power and the grid to reach the set temperature within the set time.

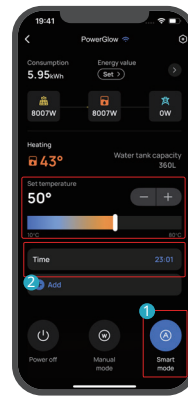

NOTICE

- If you use the PowerGlow without connecting EcoFlow App, the water tank capacity is set to be 0 L by default, the PowerGlow will operate at constant power (maximum power).

SCHEDULED TANK STERILIZATION

- During the scheduled disinfection task, the PowerGlow will operate at the rated power, and automatically switches to the set mode after sterilization, avoiding unnecessary heating power consumption drawn from the grid.
- During the scheduled disinfection task, the PowerGlow will heat the water to 75°C degrees for 3 minutes.
- Disinfection will start at your set time and repeat once, daily, or weekly as your needs.

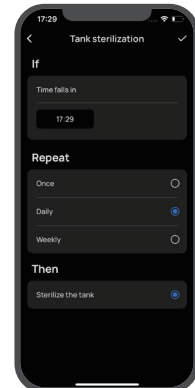
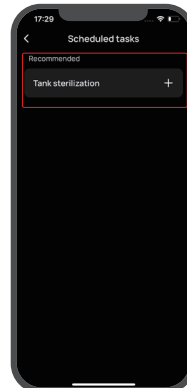
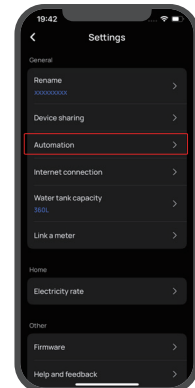
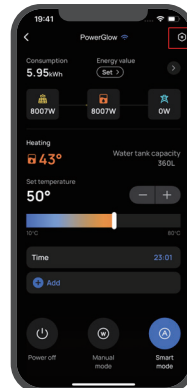

SELF CHECK FUNCTION

- EcoFlow PowerGlow comes with self-check function to prevent dry burning.
- Each time you turn on your PowerGlow after a power outage or a power-off, it will perform a 2-3 minute self-check automatically, the heating mode, meanwhile, cannot be switched. Once complete, your PowerGlow will resume operating in the set mode.

⚠ WARNING

- Do not attempt to turn on or off your PowerGlow when self-check is in progress to avoid damaging the device.
- Ensure that the heating elements are completely surrounded by water, and must not be used in dry mode under any circumstances.

Maintenance

SYSTEM POWER-OFF

⚠ WARNING

- Before installing, operating, and maintaining the equipment, always disconnect it from all power.
- The POWER SWITCH enables/disables heating function only, to de-energize the device completely, power off the AC breaker/RCD that directly connects to the device.
- Personnel who plan to install or maintain EcoFlow equipment must receive thorough training, understand all necessary safety precautions, and be able to correctly perform all operations.
- Personnel who will install, operate, and maintain the equipment, including operators, trained personnel, and professionals, should possess the local national required qualifications in special operations such as high-voltage operations, working at heights, and operations of special equipment.

PROCEDURE (INTEGRATED WITH POWEROCEAN)

- Set the POWER SWITCH to O position.
- Power off the AC breaker/RCD that directly connects to the device.
- Power off the PowerOcean system. See the installation guide that comes with PowerOcean.
- Ensure the LCD display is off.

PROCEDURE (INTEGRATED WITH THIRD-PARTY PV SYSTEM)

- Set the POWER SWITCH to O position.
- Power off the AC breaker/RCD that directly connects to the device.
- Power off the third-party PV system.
- Ensure the LCD display is off.

ROUTINE MAINTENANCE

⚠ WARNING

- Always disconnect the equipment from all power before any operation.
 - Wear proper PPE before any operations.
- Set the POWER SWITCH to O position.
 - Turn the control thermostat knob to the full left position.
 - Place temporary warning signs or erect fences to prevent unauthorized access to the maintenance site or unintentional Power-On. If the equipment is faulty, contact your dealer.
 - The equipment can be powered on only after all faults are rectified. Failing to do so may escalate faults or damage the equipment.

Check Item	Check Method	Recommended Maintenance Interval
System cleanliness	Check periodically that the heat sinks are free from obstacles and dust. If there is any stain/dirt, use a dry, soft cloth to wipe it off and prohibit the use of stain removing powder, any liquid, coarse brush, abrasives or hard objects to clean the equipment. Ensure equipment ventilation and heat dissipation.	Once every 6 months
System running status	Check that the equipment is not damaged or deformed. Check that the equipment operates with no abnormal sound. Check that all equipment parameters are correctly set during operation.	Once every 6 months

Electrical connection	Check that cables are secured. Check that cables are intact.	Once every 6 months
Grounding reliability	Check that ground cables are securely connected.	Once every 6 months
Seal ability	Check that unused terminals, ports, waterproof covers are locked as delivered.	Once every 6 months
Descaling	Descalate the heating element once a year using suitable agents, the water in the tank must be drained for this purpose.	Once every year

TROUBLESHOOTING

⚠ WARNING

- Only professionals with appropriate qualifications are allowed to perform the following activities.
 - Wear proper PPE before any operations.
- Visit and log in to the EcoFlow App.
 - Retrieve the error code and in-app instructions.
 - Completely power off the entire system, see the **System Power-Off**.
 - Follow the in-app instructions to fix the issue.



As end users, you can visit and log in to the EcoFlow user app and find the most common FAQ or contact customer support on the **Setting page -Help and feedback**.

If the problem persists, contact the EcoFlow technical support team.

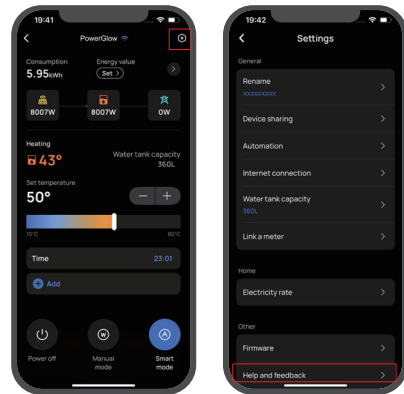

Decommissioning

⚠ CAUTION

- Before removing a heater, power it off. For details, see **System Power-Off**.

REMOVING AN IMMERSION HEATER

- Sequentially disconnect AC IN cables, communication cables and all modules connecting to the equipment including the AC breaker/RCD.
- Turn the control thermostat knob to the full left position.
- Remove the equipment from the water tank.
- Pack and store the equipment properly.

DISPOSING AN IMMERSION HEATER



If the equipment cannot work anymore, dispose of it according to the local disposal rules for electrical equipment waste. The equipment cannot be disposed of together with household waste. For details about disposal, see the **Disposal** section in this document.

Technical Parameters

Technical parameters		EF RD-P3-3K5-S1	EF RD-P3-6K0-S1	EF RD-P3-9K0-S1	
General	Heating Power (W)	3500	6000	9000	
	Fuse Protection (A)	3*25			
	Mains Connection	Single phase, 230V~, 50Hz-60Hz	Three phase, 400V 3N~, 50Hz-60Hz		
		Three phase, 400V 3N~, 50Hz-60Hz			
	Standby Consumption (W)	2			
	Efficiency	>99% at nominal power			
	Remote control, Monitoring, Management	Via EcoFlow App			
	Operating Temperature Range (°C)	0 to 40 (at the casing)			
	Storage Temperature Range (°C)	-20 to 70			
	Operating Humidity	0%-99% (Non-Condensing)			
	Maximum Operating Pressure (bar)	10			
	Net Weight (kg)	Approximately 2.7	Approximately 2.9	Approximately 3.1	
	Dimensions (WxDxH) (mm)	527x134x164 (incl. heating rod)	702x134x164 (incl. heating rod)		
	Communication	Ethernet RJ45, Wi-Fi, RS485, Bluetooth			
	2.4G Wi-Fi Frequency Range (MHz), Maximum Output Power (dBm)	2412-2472, 15.58			
	2.4G Bluetooth Frequency Range (MHz), Maximum Output Power (dBm)	2402-2480, 8.09			
Display	LED Screen with temp.				
Protection Class	IP21				
Heating Rod Thread	Screw-In Thread Dimension	G 1 1/2" (DE), G 1 3/4" or G 2 1/4" (UK)			
	Width Across Flats (mm)	55			
	Tightening Torque (Nm)	50			
Heating Rod	Heating Rod Length (mm) (from the sealing)	375	550	550	
	Heat-Free Length (mm)	33			
	Continuous Operation	Supported			
	Galvanic Isolation	Supported			
	Application	Heat exchange closed water heater			
	Mounting	Horizontal			
Temperature Control	External Temperature Sensor	2m			
	Type	Temperature acquisition + safety temperature control			
	Adjustable Temperature Range (°C)	10-80			
Compliance	Heating Cut-Out Temperature (°C)	85			
	Certificates	CE			

